

Replacing ^{GB} RES-102/RES-420

Replacement Instructions



The RESISTRON temperature controller RES-420 can be used as an alternative to the older controller type RES-102. The mechanical outlines are identical. The connection of the electrical terminals is different and must be changed acc. the described wiring diagram. The steps that are necessary to convert from RES-102-0-x (standard model without modifications) to RES-420 are described below.

These instructions only provide a brief overview of the two controllers. If in doubt, please refer to the latest version of the controller documentation, which is always binding.



The conversion from controller types RES-102-1-x is not described here. Please contact ROPEX for further informations.

Comparison of RES-102 / RES-420

Dimensions

The front panel cutout dimensions of the RES-2xx and RES-420 controllers are identical. The RES-420 fea-

tures a protective film to IP42 instead of the transparent hood. A transparent front cover featuring IP65 is available as a option.

RES-102	RES-420
	

Temperature indication (actual value)

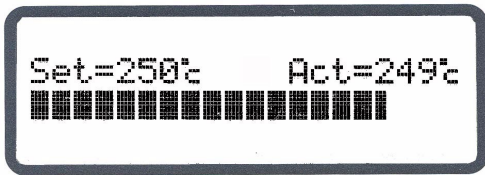
RES-102	RES-420
Indication on a analog instrument (ATR-x).	Indication on the 4-line display (dynamic bar and digital value).
	

23.1.04

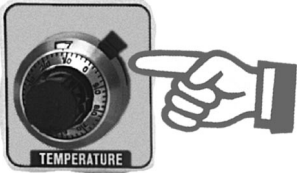
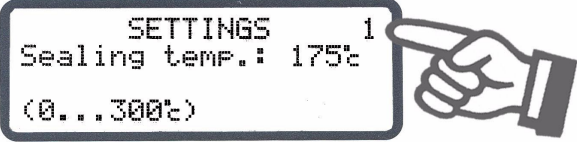

Set point selection

<p>RES-102 Selection by means of a 10-turn potentiometer with a fine control knob.</p>	<p>RES-420 Selection with step 1 in the software menu. If the controller is active, the set point is also indicated on the display.</p>
	

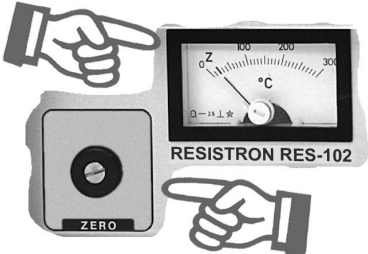
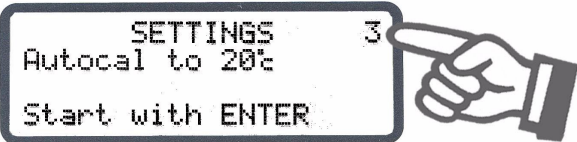

Zero calibration

<p>RES-102 Zero calibration by means of a 10-turn potentiometer. The pointer of the indicating instrument must be set to „Z“.</p>	<p>RES-420 Automatic zero calibration (AUTOCAL) with step 3 in the software menu.</p>
	

Alarm output / reset

<p>RES-102 Indicated by means of a red ALARM LED on the front panel. Reset by pressing the RESET key.</p>	<p>RES-420 Indicated on the display. The error is identified by a numeric code (↪ RES-420 documentation). Reset by pressing the RESET key ().</p>
	

Manual mode

<p>RES-102 Selected by pressing the HAND key. The red ON LED is lit continuously.</p>	<p>RES-440 Selected by pressing the HAND key () while the Home position is displayed.</p>
	

Line frequency setting (50/60Hz)

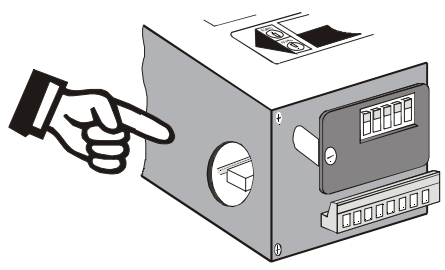
<p>RES-102 Configured with plug-in jumper.</p>	<p>RES-420 Detected automatically in the 47...63Hz range.</p>
	<p>Automatic detection</p>

Installation and setup

! Installation and startup may only be performed by technically trained, skilled persons who are familiar with the associated risks and warranty provisions.

The information provided here offers no more than a brief overview. If in doubt, please refer to the latest version of the controller documentation, which is always binding (see also section „Safety and warning notes“ of the RES-420 documentation).

Proceed as follows to replace the RES-102 controller and install/start up the RES-420:

1. Switch off the line voltage and verify the safe isolation from the supply.
2. Remove the existing RES-102 controller.
3. The supply voltage specified on the nameplate of the RES-420 controller must be identical to the line voltage that is present in the plant or machine. The line frequency is automatically detected by the temperature controller in the range from 47 to 63Hz.
4. Set the DIP switches on the RES-420.

! The settings of the DIP switches on the RES-420 are NOT the same as on the RES-102. Please set these switches in accordance with the ROPEX Application Report in order to avoid malfunctions.

Old setting ranges on the RES-102:

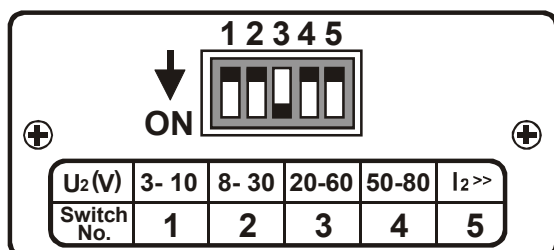

New setting ranges on the RES-420:

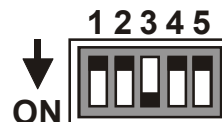

DIP-SWITCH ON	1	2	3	4	5	I ₂ (A)
U ₂ (V)	1-10	6-60	20-120	OFF ON ON	OFF OFF ON	30 - 100 60 - 200 120 - 400

The table below compares the two controllers. These settings can be taken as a guide (e.g. when the controller is started up for the first time):

	RES-102	RES-420
	DIP switch ON	
U ₂	1	1
	2	2
	3	3
	4	3
I ₂	5	4

5. Install the RES-420 controller in place of the RES-102.

! The connection of the electrical terminals is different and must be changed acc. the described wiring diagram.

6. Switch on the line voltage.
7. A power-up message appears on the display when the controller is switched on to indicate that it has been started up correctly.

8. One of the following states then appears:

DISPLAY	ACTION
Home position Shows the SET and ACTUAL temperatures or the dynamic bar	Go to 9
Shows error code 104, 106, 109 or 211	Go to 9
Shows error code 101...103, 201...203, 801 or 9xx	Fault diagnosis (↪ RES-420 documentation)

9. Select the language and reset the controller to the factory settings.

Press the key for at least 2s (to open the Configuration menu). Step 20 is displayed. Select the desired language with the keys. Confirm your selection by pressing . Press the key to display step 21 (factory settings). Press the key to confirm the factory settings (an acknowledgment message appears). Step 22 is displayed next.

10. Set the temperature range to 500°C
(Only if you have so far been using an RES-102-0-5 controller)

Then set "Alloy 20, max 500°C" with the keys in step 22. Confirm your selection by pressing .

11. Return to the Home position

Press the key for at least 2s (to return to the Home position or Alarm menu).

12. Calibrate the zero point

Activate the AUTOCAL function while the heat-sealing band is still cold.

Press the key repeatedly until step 3 is displayed. Then select the AUTOCAL function by pressing the key. If this function is executed correctly, the Home position is displayed again automatically.

If the zero has not been calibrated successfully, an error message appears on the display. In this case the controller configuration is incorrect (↪ see section „Controller configuration“ of the RES-420 documentation and the ROPEX Application Report). Configure the controller correctly and repeat the AUTOCAL function.

13. Set the heatsealing temperature (select the set point)

Press the key briefly (to display step 1 in the Setting menu). Set the required temperature with the keys. Confirm your selection by pressing . Press the key for at least 2s (to return to the Home position). The set heatsealing temperature is displayed in the Home position.

Then activate the "START" signal (HEAT). The indication on the display (actual value and dynamic bar) permits the heating and control process to be observed:

If an error code is displayed, please proceed as described in section „Error messages“ of the RES-420 documentation.

The controller is now ready

RES-420 factory settings / as-delivered condition

If you accept the factory settings (step 21 in the software menu, see step 9 above), the following defaults are restored:

Menu step	Function	Value
1	Heatsealing temperature	0°C
2	Hold mode	OFF
22	Alloy/range	Alloy A20, max. 300°C

23	Maximum temperature	300°C
24	Cycle counter	0
25	Alarm relay	Closed by alarm

The selected language (step 20 in the software menu) remains set regardless of the factory settings.

As-delivered condition:

The RES-420 controller is delivered with the above factory settings and with the language set to "German".

Wiring diagram of the RES-102 (old)

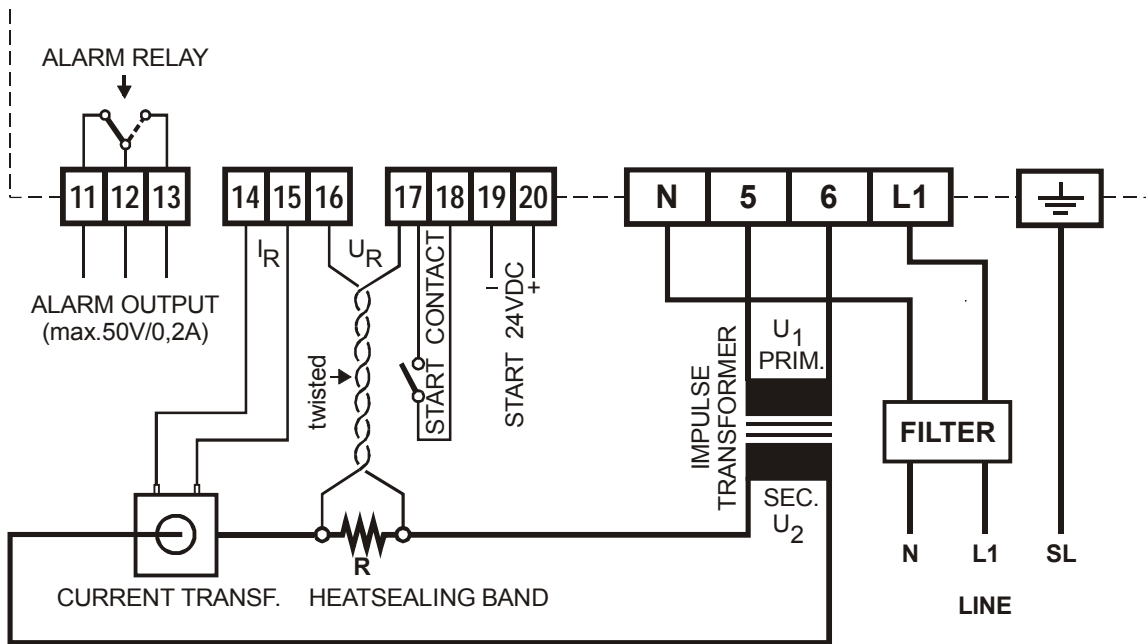

Wiring diagram of the RES-420 (new)

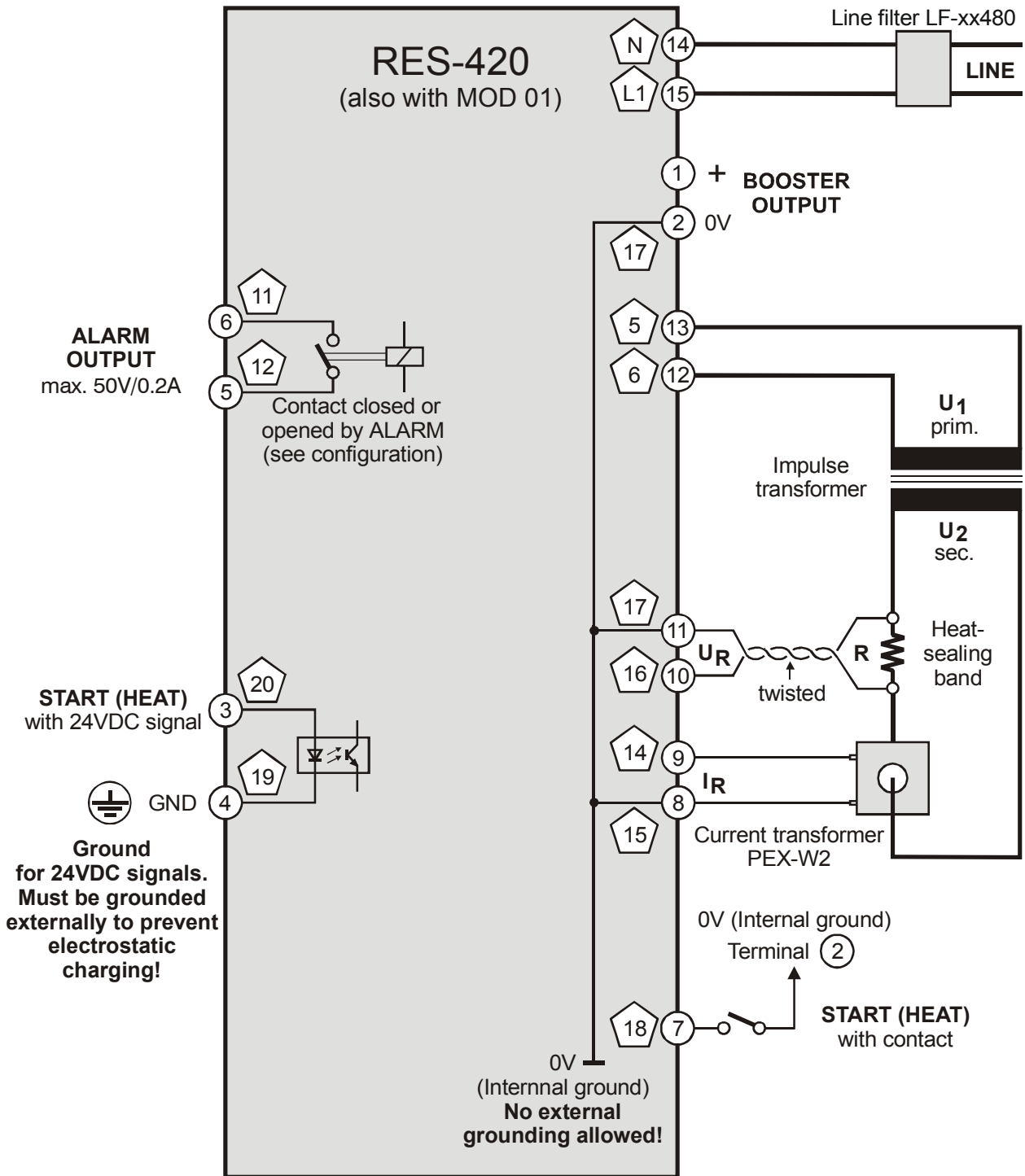

Terminal blocks
RES-102

Disconnect the ground wire connection (SL):
The ground wire connection (SL) of the RES-102 is not used for the RES-420. The RES-420 has a plastic front cover.

Menu structure of the RES-420

